

Slip Mounted Single Point Deformed Structural Skins

PAUL STOCKHOFF

University of North Carolina at Charlotte

CHRISTOPER BEORKREM

University of North Carolina at Charlotte

MARLENA MCCALL

University of North Carolina at Charlotte

ANDREW BERES

University of North Carolina at Charlotte

Slip Mounted Single Point Deformation (SMSPD) allows panels to be incrementally formed out of sheet metal into doubly-curved complex shapes using a robotic arm and a stylus-like end effector. SMSPD leverages industrial robots' precision and strength by gradually pushing the end effector into vertically supported sheet metal. SMSPD investigates material types, end effector refinement, and tool path generation, as well how fixturing of the material plays into the final form generation.

INTRODUCTION

Slip Mounted Single Point Deformation expands upon the ideas of single point incremental metal forming, using a 6-axis robotic arm, by exploring the possibilities of how sheet metal can be deformed with minimal support bracing. The goal of this technique and research is to develop controlled methods for fabricating precise, double-curved, structural panels. The slip mounted technique requires mounting a piece of material in the vertical plane while only bracing two edges of the sheet. The material in this method is allowed to stretch, flex and twist during forming unlike in traditional incremental metal forming.

Single point incremental forming is the process in which a hardened metal stylus is attached to either a robotic arm or CNC machine and then programmed to trace the contours of a shape gradually into a piece of sheet metal, allowing for far more complex shapes than traditional forming methods. While each pass is made the piece of equipment pushes between .3mm – 1mm causing the sheet to deform into the desired geometry. During the development period of the single point incremental forming process, we identified three control variables; tool design, tool path generation, and the deformation limits of 20-gauge cold rolled steel sheets for doubly-curved surfaces. This initial research, along with explorations by others, became the underpinning for the work examined in this paper, where single point incremental metal forming is used to create doubly-curved panels which can create a self-supporting structural surface.

The initial catalyst for this project began with Ammar Kalo and Michael Jake Newsum's work in robotic-based incremental metal forming. Their

work created a proof of concept for the idea of incremental metal forming made with an industrial grade robotic arm. Their work consisted of showcasing the basics needed to get incremental metal forming to work. They demonstrated how to fixture the material and offered a starting point on tool design.¹ Their tool design uses a spherical end attached to a piece of steel, which then attaches to a robotic arm. Centre of Information Technology and Architecture's (CITA) Stressed Skins and a Bridge Too Far introduced the idea that these panels could be used together to form installation scale pieces. CITA focuses on three different levels in regards to incremental metal forming, macro, meso, and micro.² By focusing their efforts at these three scales CITA defined a clear understanding of how the sheet metal will deform and also methods for creating stable geometry at the scale of the cross section of the sheet of metal to an assembly of parts. Phillip Azariadis and Nikos Aspragathos' work touches on the elasticity or stretch required to create doubly-curved panels.³

TOOL DESIGN

The tool created for the forming process went through several iterations, each of which progressively minimized artifact creation and created a better surface finish. The tool itself is attached to the end effector of the arm by an ER32 collet. Early tool iterations used a piece of high-speed steel that had been ground to a tapered rounded point. These early iterations created too much friction because the finish of the tools was not fine enough compared to the surface finish of the steel. The next iteration was finished with 220 grit, 400 grit, 600 grit sandpapers, and finally emery cloth. The improved surface quality reduced artifacts and the amount of friction generated during the forming process. Nevertheless, the finish of the part did not create an acceptable level of finish quality on the tool. The next iteration of the tool used a piece of ½" steel rod that was center drilled to accept a small magnet, which in turn would hold a 3/8" ball bearing. The ball bearing is held tightly enough so that it remains attached to the end of the tool, but maintains enough freedom to spin in place, much like a ballpoint pen. This method greatly increased the quality of the surface panel because the ball bearing is free to spin were the tool assembly to start to bind up during the forming process. Additionally, the surface finish of the ball bearing is of high enough finish to help the tool avoid artifacts and chatter marks.

TOOL PATHS

The tool paths generated to operate the robot arm used for the forming of the panels are based on four different ideas, but all focused on the overarching objective of creating the smoothest possible surface finish. Each type of tool path generation has advantages and disadvantages as expected from any type of CAM or robotic tool path generation.

STANDARD CONTOURING

Contoured tool path generation works by slicing up a surface or polysurface into sections that determine the quality of the final piece, much like a topographic drawing. Slicing increments range between 0.3mm and 1mm were tested to decrease the time needed for each panel, while balancing the amount of precision in the final surface formation. Once the contours are created then they are divided up to create points. The amount of points also increases or decreases the accuracy of the final surface produced. The final step is to create tangential planes at each respective point, rotated to be parallel to the face of the unformed steel sheet.

Advantages and Disadvantages (Standard Contouring)

- Run time of 5-15 minutes depending on depth and quality for a 16" square piece
- Creates an accurate form with minimal spring back.
- Works with all types of surface geometry
- One side will show almost no tool marks if step over is kept below .3mm. However, a small indentation is made where the robotic arm "steps down" to the next contour line during forming.
- Tearing is avoided if draft angle is kept below 55 degrees
- Transfers between multiple low spots must be programmed

STEPPED PARALLEL FINISHING

Stepped parallel finishing was tested in response to contouring's inability to handle multiple low points, without individual repairs to the tool paths. With this process a surface is scaled in one direction multiple times, so that it is nearly flat in the beginning. Each time the surface is scaled it is also contoured. Contours are then divided into points and converted into planes. This process allows a doubly-curved surface to be made without having to build multiple files.

Advantages and Disadvantages (Stepped Parallel Finishing)

- Run time of 15-30 minutes depending on depth and quality for a 16" square piece
- Causes sheet to have a distinct bow in one direction.
- Works with all types of geometries
- Tool marks are visible and distinct. Not the best method for finish pieces.
- Tearing does occur where the tool makes multiple passes in similar locations.
- Useful for initial experimentation, not practical enough to move forward.

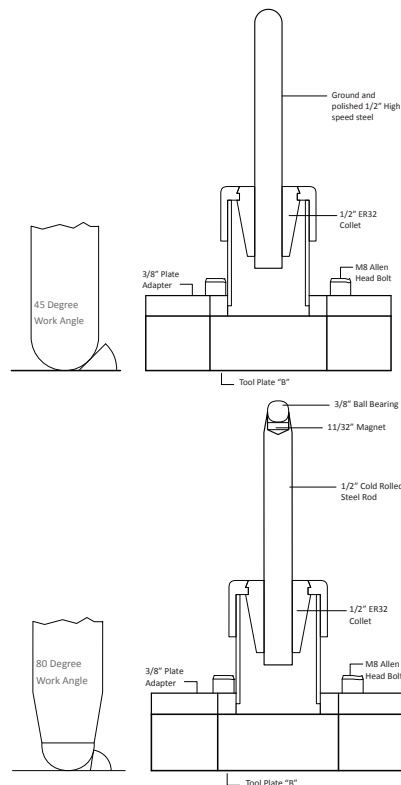

Figure 1: Progression of forming tools used during the exploration of single point incremental metal forming. First iteration (Bottom) Last iteration (Top)

STEPPED CONTOURING

Stepped contouring is an advanced version of standard contouring. The distinction with this process is done by taking the same set of contours, flattening them into the same plane, then incrementally moving them back from the plane while reducing the number of contours on each pass. This process created much higher quality final pieces but required programming repairs in instances where the surface design has multiple unconnected maximum or extreme deformations.

Advantages and Disadvantages (Stepped Contouring)

- Run time of 25-45 minutes depending on depth and quality for a 16" square piece
- Gradually pushes the metal and offers little spring back and makes for accurately formed pieces.
- Works with all types of geometries
- Tool marks are barely visible, and this process offers very high quality surface finish.
- Tearing is avoided if draft angle is kept below 55 degrees.
- While useful for experimentation, not practical enough to carry forth do the time needed to construct a single panel.

HELICAL FORMATION

Helix based tool paths offer up some of the best quality pieces in the least amount of time. This process works by placing a curve that gradually spirals down the inside of a surface. The spacing between rings can

be controlled which allows for maximum control over the quality of the finished piece. Currently, the only geometry that has tested successfully with this technique is circle based. In some cases circles can be distorted and formed into other profiles. Similar to other tool paths, once a curve is created it can then be turned into points and then planes. Further exploration with this method could be used to create more formal options.

Advantages and Disadvantages (Helical formation)

- Run time of 5-15 minutes depending on depth and quality for a 16" square piece
- Makes accurate formation with minimal spring back.
- Works with geometry based on circles. Hexagons and pentagons work if the line work created to make the surface is a rebuilt circle that gets overlaid onto the above mentioned shape.
- One side will show almost no tool marks if step over is kept below .3mm creating a near perfect finish.
- Tearing is avoided if draft angle is kept below 55 degrees
- Transfers between multiple low spots must be programmed, but quality of finish makes it worth it.

ROBOT CELL SETUP

Traditionally, single point metal forming relies on a ridged frame to hold the work in a way that limits twisting and unwanted deformation of the sheet metal. A vertical outer steel frame bolted to the floor, accepts another smaller inner frame, which in turn is used to orientate and keep the panels straight. These frames sandwich the piece of sheet metal by through-bolting the frames together. Instead of restricting movement of the sheet and forcing the metal into a desired shape, Slip Mounted Single Point Deformed Structural Skins(SMSPDS) allow the sheet metal to shift and twist during forming. While this allows for a greater amount of deformation to occur it also allows for a greater amount of forming depth to occur when compared to rigid forming practices.

In slip forming the sheet is pinched only at the top and bottom of the sheet. By reducing the amount of clamping area used to hold the sheet, it allows the material to stretch and twist thereby reacting more in response to the force of the forming tool. This freedom also allows the entire unsupported part of the sheet to be formed and bent instead of only the worked area accessible in a fully framed sheet. Additionally, the amount of wasted material is minimized as only two edges need to be trimmed post forming as opposed to the four edges in a fully framed sheet.

The relationship of distance and orientation between the robotic arm and the frame is critical to successful forming. The arm needs enough room to move into position to form the panel, without being obstructed by the frame while not pushing the arm to the limits of its reach. Due to the force needed for the arm to push against the metal it is optimal to use the major axes of the robot nearest the floor mount (axis one through axis three) because they are the larger and more powerful motors. The amount of force the robot is able to apply to the system



Figure 2: Metal forming stand used for both rigid and slip mounted forming.

varies greatly based on orientation and the number of motors working in a given instance. While it is nearly impossible to coordinate maximum effort throughout a program, the orientation of the panel relative to the arm can ensure that these larger motors are in use more frequently. Even while the larger motors are doing the majority of forming and have proper orientation the robotic arm can trip load limit switches during the routine as the metal has stiffened during the forming process, due to the geometry of the piece becoming too steep to form. When a piece of sheet metal has been formed to such an extreme the sheet starts acting in a similar way to how a piece of angle iron operates.

GEOMETRIC LIMITATIONS

Doubly-curved geometry in steel, as in most materials, is one of the more complex and time intensive geometries to fabricate. It typically requires a large time investment in the actual forming or in the production of stamping dies. For example, doubly-curved panels produced by hand by a skilled fabricator can take hours. The fabricator must slowly (and imprecisely) finesse the sheet metal into the desired form typically using a English wheel or other metal forming equipment. This is at best a slow process, and at worst highly inaccurate even when done by a professional with years of experience. The use of stamping dies allows for quick production, but those dies can only produce a single form, requiring a unique die for each panel shape.

Unlike developable or ruled surfaces, which can be laid out onto a flat sheets and then formed, the amount of material needed for doubly-curved forms can only be estimated. Because only estimates of the amount of material needed for a doubly-curved surface can be made, extra material must be used in forming and then later trimmed.

Slip mounted incremental forming starts to address many of the problems caused by the inaccuracies of attempting to make doubly-curved surfaces. By clamping only the top and bottom edge of the piece of metal to a rigid frame, the amount of material needed for forming can be minimized because a constraint is being removed and a new variable is being added. Additionally, the non-clamped sides do not require any trimming to bring them into alignment, this edge condition can be predicted computationally before forming commences.

PRE-TRIMMING

Using a two-dimensional CNC plasma cutter, we began testing methods for pre-trimming panels before they are formed. This process avoids the costly and inaccurate process of attempting to trim doubly-curved panels after forming. Additionally, this process greatly decreases the amount of wasted material by being able to nest many panels near each other in a sheet. Because of the inability to predict the final edge conditions in other methods, significant amounts of materials were left to accommodate mounting and trimming. Through a series of tests and verifications we were able to accurately predict the deformations of the edge conditions of given sheet computationally, and reverse engineer new panel shapes to predict their required two-dimensional shape before forming.

VERIFICATION

The process of verification required a feedback loop which balanced the amount of deformation in the sheet which pulled from the existing panel and the amount of thinning or stretching in the steel. The feedback loop was constructed by using both a 3D scanner and a 3D digitizer to create models of formed pieces, which were then tested against the original digital model employed to generate the routine for the robotic arm. After forming is complete, a 3D digitizer is used to translate the now formed part back into a 3D modeling environment. This process includes tracing over a set of grid lines drawn onto the back of each panel before forming began. This provides a set of line work, which can be used to create a model. By testing along two-dimensional lines we are able to monitor the specific amount of stretching which occurred along that axis, compared with the amount of forming. The contrast between the contour of the robotic arm movement, the final form along that axis, and the original amount of material along that axis, created a series of diagrams that we could use to estimate the reactions of the metal to particular geometries.

In addition to the scanner, an infra-red 3D scan is taken of each panel. The 3D scan produces a field of points, which were converted into a surface to be tested against the computational surface geometry used to form the panel. The test makes use of both modeling types to help average out any inaccuracy in both the measuring and modeling technique. It also allows for the measurement of three-dimensional deformations that maybe occurring within a given surface. The actual test will have each of the two reconstructed models centered on the forming geometry. At that point a field of points will be projected onto the three separate surfaces from the same XY coordinates. Once projected onto the surfaces the Z-axis values from the two reconstructed surfaces can be averaged and then divided by the actual Z-axis value. This deformation created values that can be used to calculate the amount of stressed induce thinning in the sheet and compare it to the amount of forming which was created along the same contour.

The forming model is parametrically defined, so that small adjustments can be made to the surface with little effort. This offers the ability to check for changes over an extended set of panel tests. Through an extensive series of panel test we developed an approximate calculable understanding of how the metal reacts during forming. The understanding gained by this feedback loop also allows for a panel to be formed to an exact finished dimension instead of requiring additional material to be

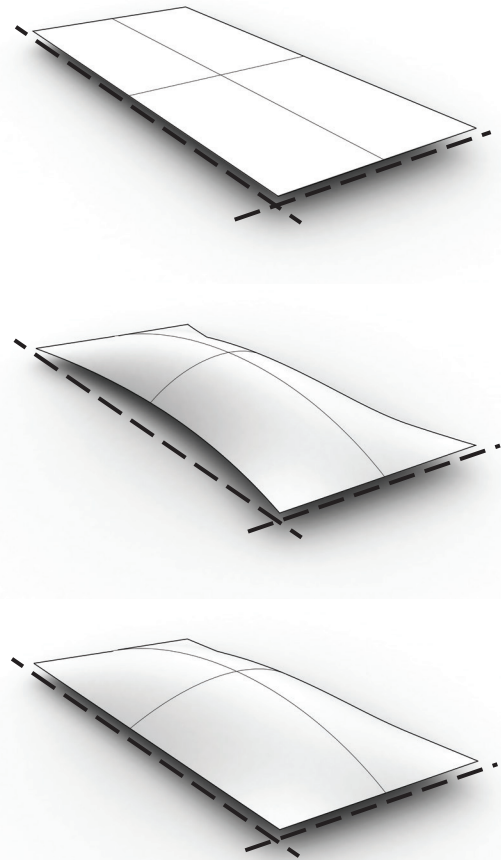

Figure 3: Diagrams of: (Top) Unformed uncorrected blank. (Middle) Formed uncorrected panel. (Bottom) Formed corrected panel.

removed. From this point, we created a parametric model which can be used to generate both two-dimensional shapes and three-dimensional programs for tooling and forming.

FUTURE DEVELOPMENT

With doubly-curved panels able to be formed, we are proposing the fabrication of a self-supporting segmented shell structure. The proposed structure would sweep a catenary arc along a vault shape. Segments of the shell would be used to create structural sections. The segments themselves would be trapezoidal in shape to adjust for the increasing width needed to fill the space. The panels used to construct each segment are of similar shape, and they are placed in a running bond pattern to help transfer the structural load from one panel to the next. To help add greater stiffness to the form every other panel is flipped to work in compression or tension as with the 2010 ICD/ITKE Pavilion. The panels are joined by braking over the unformed segments of the sheet, which were held in the fixture. The bolt holes used for fixturing can be used to secure panels to one another. Utilizing the pre-fabricated (plasma cut) holes, which are all the same, allows for a variable to be removed, and now fabricators only must be concerned with accurately braking the panels to the right angle.

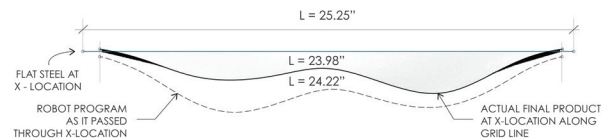

Figure 4: Expected deflection compared to actual deflection

Slip mounted single point deformed structural skins offer up a method to take single point incremental metal forming to the next level, by increasing the amount of depth available in the form and by linking the forming geometry to the geometry produced. This process allows for production of geometry which can express their structural conditions.

CONCLUSION

The process of single point incremental metal-forming to create doubly-curved geometry based on allowing the metal to react to deformations instead of forcing metal into desired conditions, creates a form more closely linked to its expressive properties. By understanding the edge geometry needed before forming, preprocessed sheets can be used, saving time and expense when compared to cutting the preformed.

With slip mounted single point deformation, a focus on constructing an installation scale piece out of a self-supporting skin constructed is possible. Joint details and the analysis of possible stable geometries can be undertaken. As panels are arranged and assembled they will inevitably undergo more deformation and stressing, which can be analyzed using similar techniques to the individual panels analyzed here.

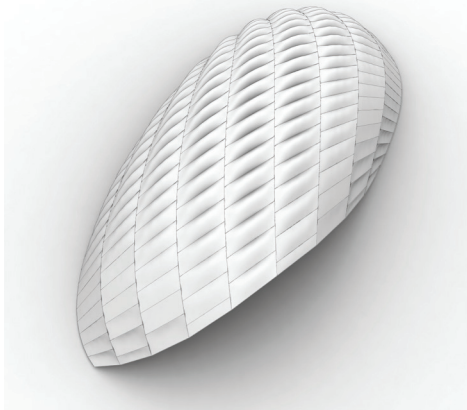
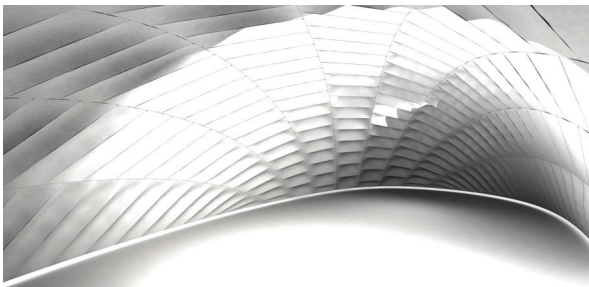

Figure 5: Proposed shell structure constructed from formed panels

ENDNOTES

1. Kalo, Ammar, and Michael Jake Newsum. "Robotic Incremental Sheet Metal Fabrication." *Robotic Fabrication in Architecture, Art and Design* 2014, 2014, 71. doi:10.1007/978-3-319-04663-1_3.
2. Azariadis, Phillip, and Nikos Aspragathos. "Design of Plane Development of Doubly-curved Surfaces." *Computer-Aided Design* Vol.29 No. 10.
3. Nicholas, Paul, David Stasiuk, Esben Clause Norgaard, Christopher Hutchinson, and Mete Ramsgaard Thomsen. "A Multiscale Adaptive Mesh Refinement Approach to Architected Steel Specification in the Design of a Frameless Stressed Skin Structure." *Modelling Behaviour: Design Modelling Symposium* 2015.
4. De Landa, Manuel. "Philosophies of Design: the Case of Modelling Software" in: *Verb: Architecture Bookazine*. Actar. January 1, 2002. Print.
5. Fleischmann, Moritz, Jan Knippers, Julian Lienhard, Achim Menges, and Simon Schleicher. "Material Behaviour: Embedding Physical Properties in Computational Design Processes." *Architectural Design* *Archit Design* 82, no. 2 (2012): 44-51. doi:10.1002/ad.1378.u.